



## Pallet Stackers

# L14 – L16 SP

Capacity 1.4 t – 1.6 t | Series 1177

PB ION H<sub>2</sub>

### Flexible lifting talent

- Versatile pallet stacker for storage and retrieval at a height of up to 5.3 metres and for longer transport journeys
- Solid steel skirt around the standing platform for effective protection in case of collision
- Unique platform concept with standing position at 45° angle and Linde e-driver control for better all-round vision and an ergonomic posture
- Linde OptiLift assistance system for precise mast control and energy-efficient load handling
- Innovative castor wheel concept for maximum stability when storing and retrieving at height

# TECHNICAL DATA (according to VDI 2198)

Characteristics	1.1	Manufacturer		Linde MH	Linde MH
	1.2	Model		L14 SP	L16 SP
	1.2a	Series		1177-00	1177-00
	1.3	Power unit		Battery	Battery
	1.4	Operation		Stand on	Stand on
	1.5	Load capacity/Load	Q (t)	1.4/(2.0) <sup>1)</sup>	1.6/(2.0) <sup>3)</sup>
	1.6	Load centre distance	c (mm)	600	600
	1.8	Axle centre to fork face	x (mm)	654/724 <sup>2) 3)</sup>	654/724 <sup>2) 3)</sup>
	1.9	Wheelbase	y (mm)	1316/1386 <sup>2) 3)</sup>	1316/1386 <sup>2) 3)</sup>
Weights	2.1	Service weight	kg	1660 <sup>4) 5)</sup>	1660 <sup>4) 5)</sup>
	2.2	Axle load with load, front/rear	kg	1763/1297 <sup>4) 5)</sup>	1954/1306 <sup>4) 5)</sup>
	2.3	Axle load without load, front/rear	kg	420/1240 <sup>4) 5)</sup>	420/1240 <sup>4) 5)</sup>
Wheels / tyres	3.1	Tyres rubber, SE, pneumatic, polyurethane		Polyurethane	Polyurethane
	3.2	Tyre size, front		Ø 254 × 102	Ø 254 × 102
	3.3	Tyre size, rear		Ø 85 × 85 (2x Ø 85 × 60) <sup>6)</sup>	Ø 85 × 85 (2x Ø 85 × 60) <sup>6)</sup>
	3.4	Auxiliary wheels (dimensions)		2x Ø 140 × 50	2x Ø 140 × 50
	3.5	Wheels, number front/rear (x = driven)		1x + 1/2 (1x + 1/4) <sup>6)</sup>	1x + 1/2 (1x + 1/4) <sup>6)</sup>
	3.6	Track width, front	b10 (mm)	491 <sup>2)</sup>	491 <sup>2)</sup>
	3.7	Track width, rear	b11 (mm)	380/500 <sup>2)</sup>	380/500 <sup>2)</sup>
Dimensions	4.2	Height of mast, lowered	h1 (mm)	2265 <sup>2)</sup>	2265 <sup>2)</sup>
	4.3	Free lift	h2 (mm)	1745 <sup>2)</sup>	1745 <sup>2)</sup>
	4.4	Lift	h3 (mm)	5316 <sup>2)</sup>	5316 <sup>2)</sup>
	4.5	Height of mast, extended	h4 (mm)	5836 <sup>2)</sup>	5836 <sup>2)</sup>
	4.6	Initial lift	h5 (mm)	115 <sup>7)</sup>	115 <sup>7)</sup>
	4.7	Height of overhead guard (cabin)	h6 (mm)	2224 <sup>2)</sup>	2224 <sup>2)</sup>
	4.9	Height of tiller arm in operating position, min/max	h14 (mm)	1207/1287 <sup>2)</sup>	2259/1357 <sup>2)</sup>
	4.10	Height of reach legs	h8 (mm)	80 <sup>8)</sup>	80 <sup>8)</sup>
	4.15	Height, lowered	h13 (mm)	86 <sup>8)</sup>	86 <sup>8)</sup>
	4.19	Overall length	l1 (mm)	2494 <sup>2)</sup>	2467 <sup>2)</sup>
	4.20	Length to fork face	l2 (mm)	1347 <sup>2)</sup>	1347 <sup>2)</sup>
	4.21	Overall width	b1/b2 (mm)	800 <sup>2)</sup>	800 <sup>2)</sup>
	4.22	Fork dimensions DIN ISO 2331	s/e/l (mm)	71 × 180 × 1150 <sup>9)</sup>	71 × 180 × 1150 <sup>9)</sup>
	4.24	Width of fork carriage	b3 (mm)	780 <sup>2)</sup>	780 <sup>2)</sup>
	4.25	Fork spread	b5 (mm)	560/680 <sup>2)</sup>	560/680 <sup>2)</sup>
	4.26	Distance between wheel arms/loading surfaces	b4 (mm)	196/316 <sup>2)</sup>	196/316 <sup>2)</sup>
	4.31	Ground clearance, below mast	m1 (mm)	135/20 <sup>3)</sup>	135/20 <sup>3)</sup>
	4.32	Ground clearance, centre of wheelbase	m2 (mm)	135/20 <sup>3)</sup>	135/20 <sup>3)</sup>
	4.34.1	Aisle width for pallets 1000 × 1200 crossways	Ast (mm)	2894/2931 <sup>3) 10)</sup>	2894/2931 <sup>3) 10)</sup>
4.34.2	Aisle width with pallet 800 × 1200 along forks	Ast (mm)	2878/2893 <sup>3) 10)</sup>	2878/2893 <sup>3) 10)</sup>	
4.35	Turning radius	Wa (mm)	2001/2071 <sup>3)</sup>	2001/2071 <sup>3)</sup>	
Performance	5.1	Travel speed, with/without load	km/h	9.5/9.5 <sup>11)</sup>	9.5/9.5 <sup>11)</sup>
	5.2	Lifting speed, with/without load	m/s	0.18/0.39 (0.57/0.89) <sup>5) 12)</sup>	0.17/0.39 (0.57/0.89) <sup>5) 12)</sup>
	5.3	Lowering speed, with/without load	m/s	0.27/0.17 (0.68/0.72) <sup>5) 12)</sup>	0.26/0.17 (0.68/0.72) <sup>5) 12)</sup>
	5.8	Maximum climbing ability, with/without load	%	-	-
	5.9	Acceleration time, with/without load	s	6.0/5.1	6.0/5.1
	5.10	Service brake		electric/mechanic	electric/mechanic
Drive	6.1	Drive motor rating at S2 60 min	kW	3	3
	6.2	Lift motor rating at S3 15%	kW	3.2	3.2
	6.3	Battery according to DIN 43531/35/36 A,B,C,no		43 535 B/3PzS	43 535 B/3PzS
	6.4	Battery voltage/rated capacity (5 h)	(V)/(Ah) o. kWh	24/375	24/375
	6.5	Battery weight (±5%)	kg	333	333
	6.6	Energy consumption according to DIN EN 16796	kWh/h	-	-
	6.6.1	CO <sub>2</sub> equivalent according to EN 16796	kg/h	-	-
	6.7	Turnover output according to VDI 2198	t/h	62.0	70.0
6.8	Turnover efficiency according to VDI 2198	t/kWh	33	35	
Others	8.1	Type of drive unit		KWPC 05	KWPC 05
	10.7	Sound pressure level LpAZ (at the operator's seat)	dB(A)	67	67

1) (Load distribution, e.g. 1000 kg on the forks, 1000 kg on the fork arms, total load max. 2000 kg)

2) (±5 mm)

3) Load arms upraised/lowered

4) Figures with battery, see line 6.4/6.5.

5) (±10%)

6) Figures in parenthesis with tandem load wheels

7) (0/-5 mm)

8) (0/+5 mm)

9) Reach legs 75 × 150 × 1115 mm

10) Including a 200 mm (min.) operating aisle clearance

11) (±5%)

12) Figures in parenthesis with initial lift

# L14 SP - L16 SP

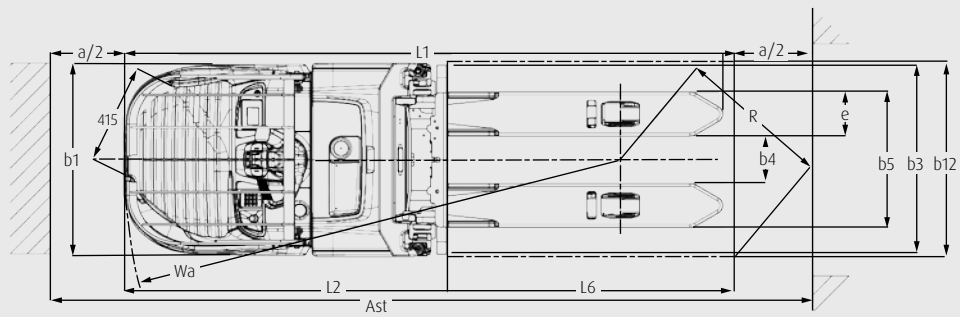
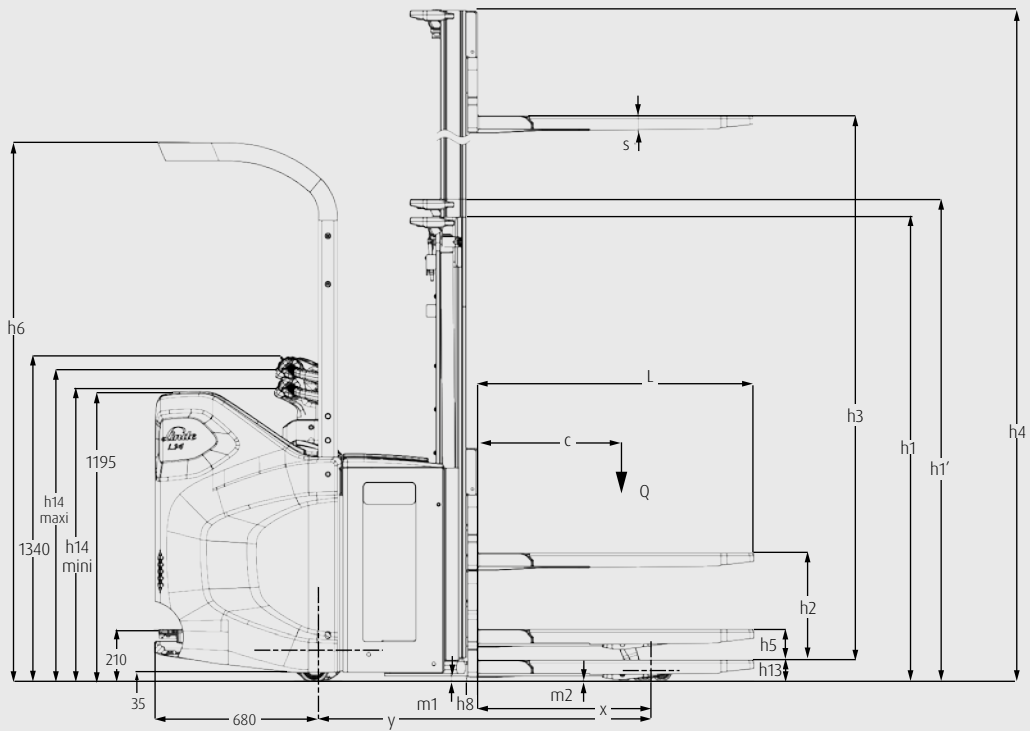

# MAST TABLES

## STANDARD MAST (in mm)

Series	1177													
Lift	h3: 1844		h3: 2344		h3: 2844		h3: 3244		h3: 3744		h3: 4144		h3: 4644	
Height measurements	h1: 1415 h3: 1844 h1': 1490	h2: 150 h4: 2364	h1: 1665 h3: 2344 h1': 1740	h2: 150 h4: 2364	h1: 1915 h3: 2844 h1': 1990	h2: 150 h4: 3364	h1: 2115 h3: 3244 h1': 2190	h2: 150 h4: 3764	h1: 2365 h3: 3744 h1': 2440	h2: 150 h4: 4264	h1: 2565 h3: 4144 h1': 2640	h2: 150 h4: 4664	h1: 2815 h3: 4644 h1': 2890	h2: 150 h4: 5164
Model														
L14 SP	<input type="radio"/>		<input type="radio"/>		<input type="radio"/>		<input type="radio"/>		<input type="radio"/>		<input type="radio"/>		<input type="radio"/>	
L16 SP	<input type="radio"/>		<input type="radio"/>		<input type="radio"/>		<input type="radio"/>		<input type="radio"/>		<input type="radio"/>		<input type="radio"/>	

## SIMPLEX MAST (in mm)

Series	1177			
Lift	h3: 1462		h3: 1612	
Height measurements	h1: 1915 h3: 1462 h1': -	h2: 1395 h4: 1982	h1: 2065 h3: 1612 h1': -	h2: 1545 h4: 2132
Model				
L14 SP	<input type="radio"/>		<input type="radio"/>	
L16 SP	<input type="radio"/>		<input type="radio"/>	

## DUPLEX MAST (in mm)

Series	1177											
Lift	h3: 1844		h3: 2344		h3: 2844		h3: 3244		h3: 3744		h3: 4144	
Height measurements	h1: 1415 h3: 1844 h1': -	h2: 895 h4: 2364	h1: 1665 h3: 2344 h1': -	h2: 1145 h4: 2864	h1: 1915 h3: 2844 h1': -	h2: 1395 h4: 3364	h1: 2115 h3: 3244 h1': -	h2: 1595 h4: 3764	h1: 2365 h3: 3744 h1': -	h2: 1845 h4: 4264	h1: 2565 h3: 4144 h1': -	h2: 2045 h4: 4664
Model												
L14 SP	<input type="radio"/>		<input type="radio"/>		<input type="radio"/>		<input type="radio"/>		<input type="radio"/>		<input type="radio"/>	
L16 SP	<input type="radio"/>		<input type="radio"/>		<input type="radio"/>		<input type="radio"/>		<input type="radio"/>		<input type="radio"/>	

## TRIPLEX MAST (in mm)

Series	1177							
Lift	h3: 3516		h3: 4266		h3: 4716		h3: 5316	
Height measurements	h1: 1665 h3: 3516 h1': -	h2: 1145 h4: 4036	h1: 1915 h3: 4266 h1': -	h2: 1395 h4: 4786	h1: 2065 h3: 4716 h1': -	h2: 1542 h4: 5236	h1: 2265 h3: 5316 h1': -	h2: 1745 h4: 5836
Model								
L14 SP	<input type="radio"/>		<input type="radio"/>		<input type="radio"/>		<input type="radio"/>	
L16 SP	<input type="radio"/>		<input type="radio"/>		<input type="radio"/>		<input type="radio"/>	

h1: Height of mast, lowered

h2: Free lift

h3: Lift

h4: Height of mast, extended

h1': Height of mast, with initial lift (+75 mm)

Optional equipment

# STANDARD AND OPTIONAL EQUIPMENT

Model / equipment		L14 SP	L16 SP
Safety	Automatic speed reduction when cornering	●	●
	Key switch	●	●
	Log in PIN code	○	○
	Unique, safe and intuitive 45° operating position	●	●
	Linde BlueSpot – optical warning signal for pedestrians and drivers	○	○
	Foot detection sensor – truck slows down or stops if operator's foot is detected outside of the platform contours	○	○
Service	CAN bus technology	●	●
Digitalisation	Data transmission online		
	Data transmission Wifi		
	Linde connect:desk – local fleet management with different functional modules	○	○
	Linde connect:cloud – fleet management as a service (hosted version)	○	○
	Linde Pre-Op Check App – individualisable daily check protocol for operational readiness	○	○
Operation/load handling	Initial lift	○	○
	Ultra-fast lifting	○	○
	Soft landing on forks	○	○
	Low speed if initial lift lowered	○	○
	Maximum operating speed limitation (8, 10, 12 km/h, depending on the model)	○	○
	Load backrest h = 1000 mm	○	○
	Overhead guard	○	○
Environment	Coldstore -35°C (in/out) – with grid or standard floor mat	○	○
Workplace	Fully suspended operator compartment – both feet platform and steering unit are suspended	●	●
	Padded leg rest and backrest	●	●
	Twin-grip handlebar	●	●
	Innovative Linde e-driver control perfectly suited for operation at a 45° angle in standing position	○	○
	Height adjustable steering unit	○	○
	Multi-function coloured display hour meter, maintenance indication, battery discharge indicator and internal fault code indication	●	●
	Accessory support	○	○
	Support for data terminal and power supply cable 24 V	○	○
	Scanner support and clipboard	○	○
	Electrical socket USB 5 V	○	○
Mast	Standard	○	○
	Simplex	○	○
	Duplex	○	○
	Triplex	○	○
	Mast protection: mesh	○	○
Attach-ment/forks	Width over fork carriage 560 mm with fork length 950 mm or 1150 mm	○	○
	Width over fork carriage 680 mm with fork length 1150 mm	○	○
Axles and tyres	Drive wheel heavy duty, polyurethane non-marking	●	●
	Drive wheel high grip, polyurethane non-marking	○	○
	Drive wheel rubber	○	○
	Single load wheel, polyurethane	●	●
	Tandem load wheel, polyurethane (also available in greasable version)	○	○
	Double castor wheel (also available in greasable version)	●	●
Drive and braking system	Power steering	●	●
	Maintenance-free AC motor	●	●
	Electromagnetic braking system (or electromechanic)	●	●
	Li-ION and lead acid technology available with different battery capacities depending on the model	○	○
	Integrated charger for lead acid and Li-ION batteries	○	○
External chargers available	○	○	
Lighting	Working lamp – with on/off switch for operation in dark environments	○	○

● Standard equipment

○ Optional equipment

# CHARACTERISTICS



Operator remains safe within the chassis contours

## Safety

- Solid steel apron around the standing platform protects the operator from injury in the event of collision
- Optimised visibility through the mast for safe load handling
- Dead man's switch and traction control for the highest possible safety in every work situation
- Foot detection automatically brings the vehicle to a smooth stop when operator's feet leave the platform
- Automatic braking when cornering to prevent risky operating manoeuvres



Ergonomic, height-adjustable tiller

## Ergonomics

- Linde OptiLift assistance system for precise control of mast functions and energy-saving load handling, even at high working speeds
- Electric power steering with adjustable steering resistance for effortless vehicle control in any work situation
- Fully decoupled and suspended operator platform to protect the operator from vibrations and shocks
- Unique design with 45° standing position and innovative steering concept Linde e-driver for optimum all-round vision without straining the back and neck
- Workstation with multifunction display and storage compartments for work utensils and personal items (optional)



Precise handling and easy manoeuvrability

## Handling

- High lifting speeds for maximum handling performance
- Ergonomic tiller with all control functions (traction motor, initial stroke, horn, etc.) for effortless vehicle handling
- High residual capacities for efficient and safe stacking and transport of large loads
- Initial lift function for better load handling on slopes, ramps or uneven ground (optional)
- Soft-landing function to protect the load from damage by gently setting down the forks



Easy access to all data with multi-function display

## Service

- Maintenance-free three-phase motor for long service intervals and permanently low maintenance costs
- Solid construction with durable parts and sturdy chassis for maximum vehicle availability
- Effortless accessibility of all relevant components thanks to consistent design-to-service principle
- Innovative CAN bus architecture for easy access to all vehicle data via diagnostic connector
- Modern E/E architecture allows remote installation of updates and new functions

Presented by:

Subject to modification in the interest of progress. Illustrations and technical details could include options and are not binding for actual constructions. All dimensions subject to usual tolerances.



## Linde Material Handling GmbH

Carl-von-Linde-Platz | 63743 Aschaffenburg | Germany  
Phone + 49 6021 99 0 | Fax + 49 6021 99 1570  
www.linde-mh.com | info@linde-mh.com

Printed in Germany | DS\_L14-L16\_SP\_1177-00\_en\_B\_0723

